

## FICHA TÉCNICA

Escalera Extensible 2X10 De Fibra De Vidrio. Carga Máx. 150Kg Altura Escalón 305Mm. Peso Aproximado: 15.9 Kg. Empacado En Bolsa De Polietileno.

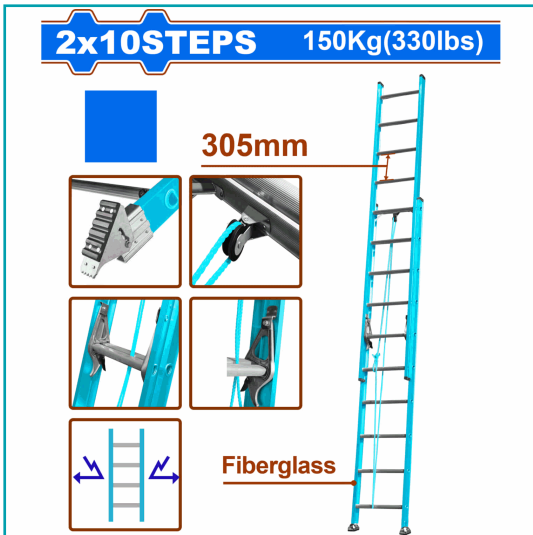

**CÓDIGO:**  
**WLD0920**

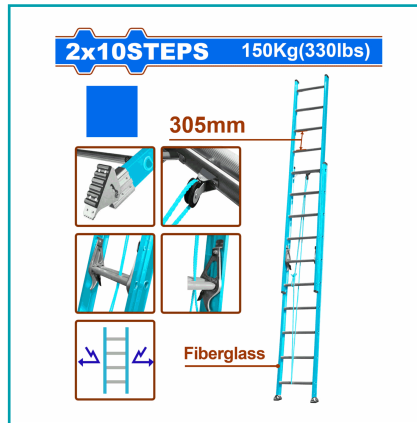

**\*Nombre:** Escalera Extensible 2x10 de fibra de vidrio

**Cantidades por caja:** Caja grande 1

**Características:** Escalera Extensible 2x10 de fibra de vidrio. Carga Máx. 150Kg Altura escalón 305mm. Peso aproximado: 15.9 kg.

**Código de Barras:** 6923736789190

**Código de producto:** WLD0920

**Color:** Azul

**Marca:** WADFOW by Total Tools

**Peso (Kg):** 15.9

**Presentación:** Bolsa de Polietileno

**Procedencia:** Importado

**Se vende por:** Unidad

**Usos:** Profesional

## INFORMACIÓN ADICIONAL

Escalera Extensible De Fibra De Vidrio.

- Material: Fibra De Vidrio.
- Número De Peldaños: 2X10
- Altura De Extensión: 5500Mm
- Altura Del Peldaño: 305Mm
- Tamaño Abierto: 450X140X5500 Mm
- Tamaño Cerrado: 450X140X3150 Mm
- Peso Aproximado: 15.9 Kg
- Carga Máxima: 150 Kg (330 Libras)
- Empacado En Bolsa De Polietileno.

## 2x10STEPS 150Kg(330lbs)



305mm

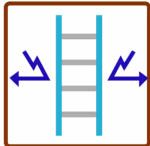

Fiberglass



## 2x10STEPS 150Kg(330lbs)



305mm

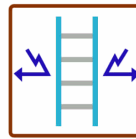
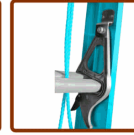
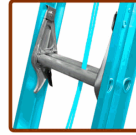

Fiberglass

